

STEELTAPP®

METAPP®

Steel Applications

METAPP®

- Carbon steel fasteners for fixing steel sheets into steel substrates

Standard Features of METAPP®

Hex Washer Flange

LEVIN™ Drill Point

Black/Grey Round Cut EPDM Washer



Powder Coated head to match the colour of roofing sheets



CORROSHIELD®
F A S T E N E R S

STEEL PENETRATION

Max. 4.5mm thick

ADAPTER TO USE

CORROSHIELD®
Hi-Torque Philips Bit

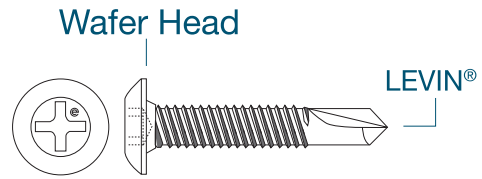

OTHER OPTION/S

Powder coated head to match the colour of roofing sheets

DESCRIPTION

Wafer Head Philips Drive
LEVIN® Drill Point

PRODUCT FEATURE/S

LEVIN® Drill Point

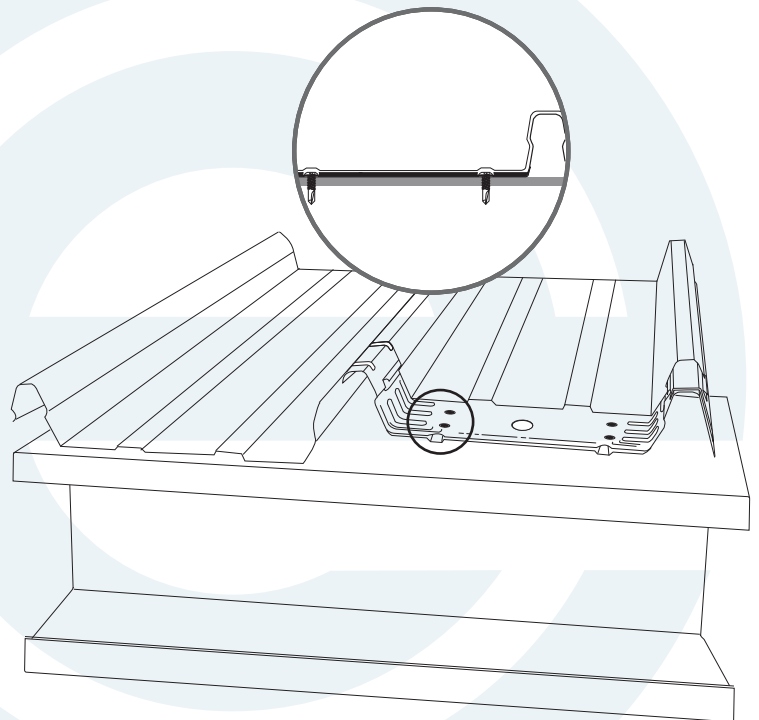

Part Number

- MT 10 - 16 x 16mm
- MT 10 - 16 x 25mm
- MT 10 - 16 x 35mm
- MT 10 - 16 x 45mm

* For size not indicated above, please contact us for further information

How to Read Our Part Number

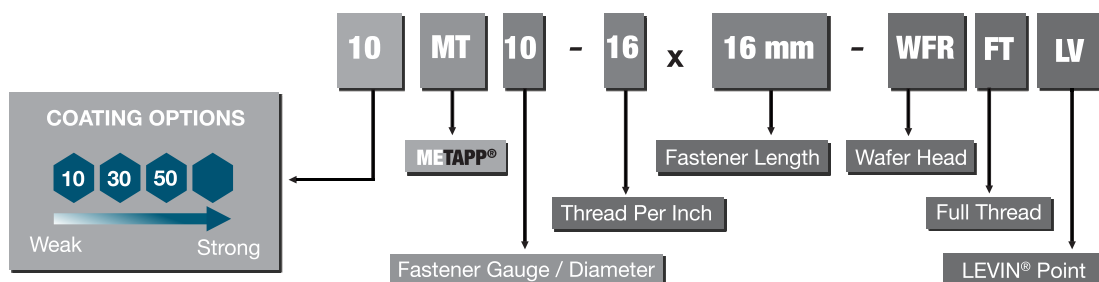

Wafer Head

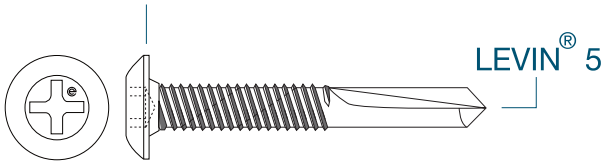

STEEL PENETRATION

Max. 10mm thick

ADAPTER TO USE

CORROSHIELD®
Hi-Torque Phillips Bit



OTHER OPTION/S

Powder coated head to match the colour of roofing sheets

DESCRIPTION

Wafer Head Phillips Drive
LEVIN® 5 Drill Point

PRODUCT FEATURE/S

LEVIN® 5 Drill Point

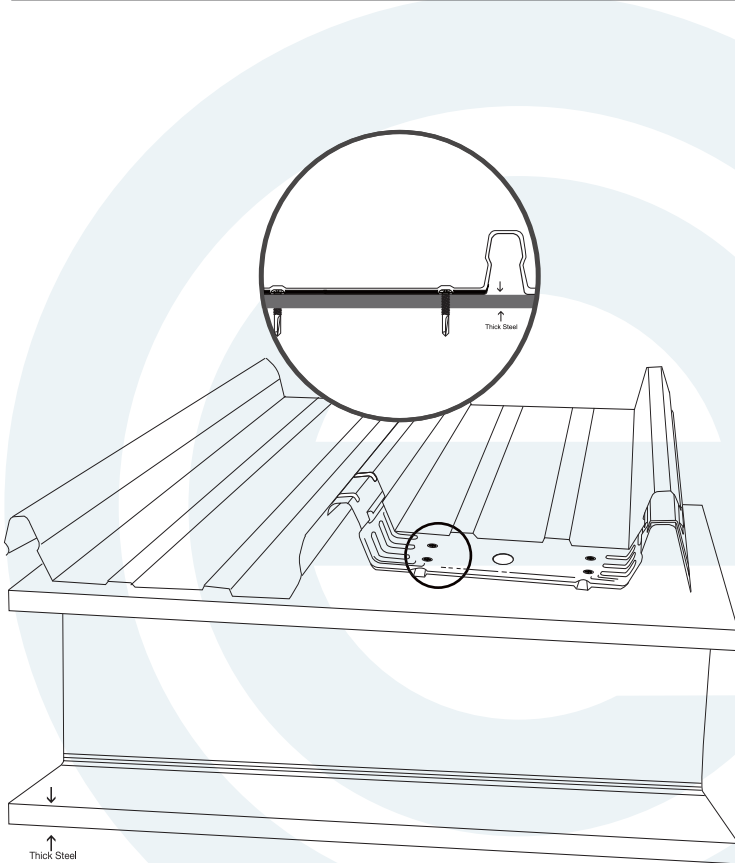

Part Number

MT 12 - 24 x 32mm

* For size not indicated above, please contact us for further information

How to Read Our Part Number

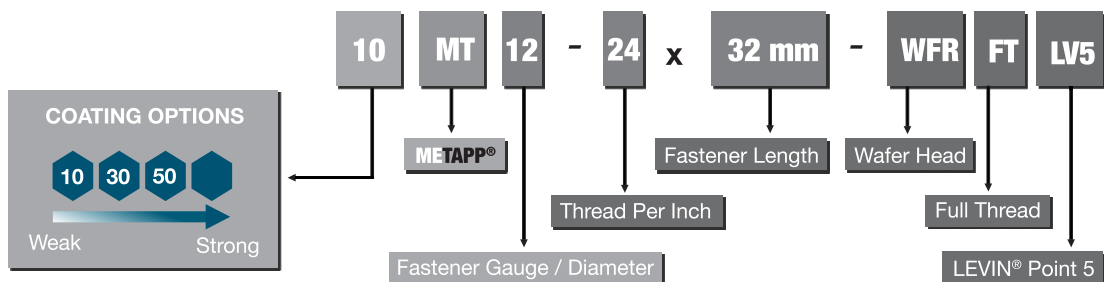

STEEL PENETRATION

Max. 1.0mm thick

ADAPTER TO USE

CORROSHIELD®
Hi-Torque Magnetic Hex Socket

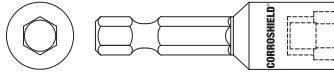

Hex Washer Flange

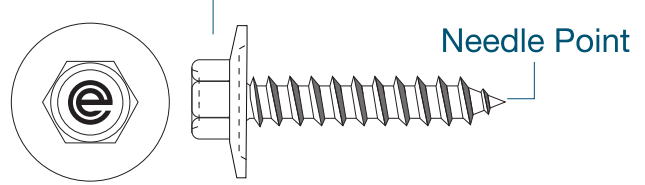

OTHER OPTION/S

Powder coated head to match the colour of roofing sheets

DESCRIPTION

Hex Washer Flange
Needle Point

PRODUCT FEATURE/S

ø 12.5mm Integrated Flange (HWF)

WASHER OPTION/S

Black/Grey Round Cut EPDM Washer

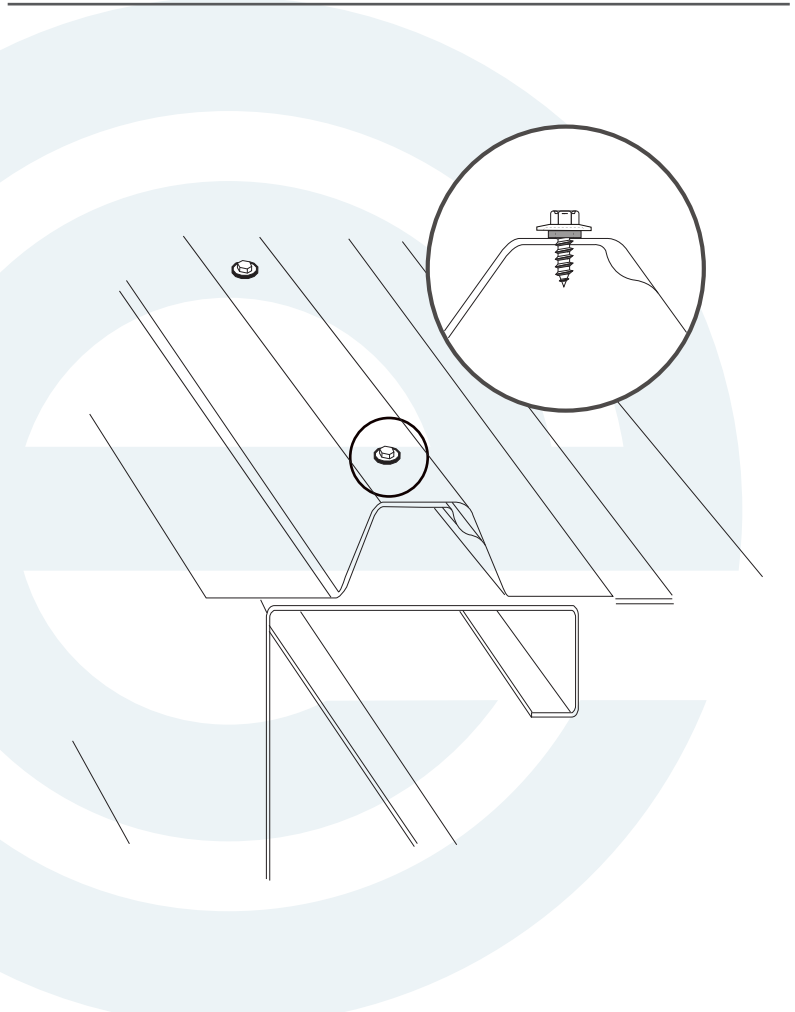

Part Number

MT 10 - 12 x 20mm

* For size not indicated above, please contact us for further information

How to Read Our Part Number

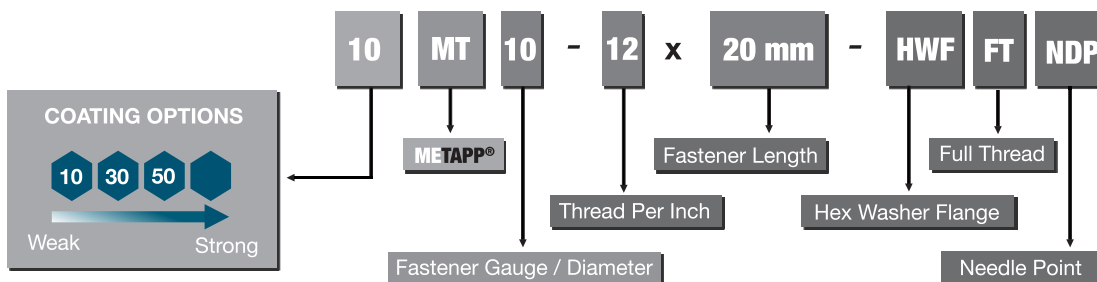

Hex Washer Flange

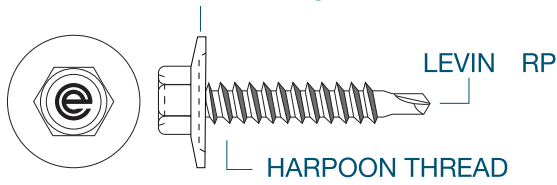

STEEL PENETRATION

Max. 1.2mm thick (For Size 10)
 Max. 1.6mm thick (For Size 12)
 Max. 2.0mm thick (For Size 14)

ADAPTER TO USE

CORROSHIELD®
 Hi-Torque Magnetic Hex Socket

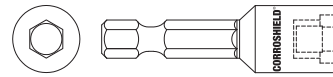

OTHER OPTION/S

Powder coated head to match the colour of roofing sheets

DESCRIPTION

Hex Washer Flange
 Harpoon Thread
 LEVIN® Reduced Drill Point

PRODUCT FEATURE/S

ø 14mm Integrated Flange (HWF)
 Harpoon Thread
 LEVIN® Reduced Drill Point

WASHER OPTION/S

Black/Grey Round Cut EPDM Washer



Part Number

MT 10 - 16 x 20mm
 MT 12 - 14 x 22mm

* For size not indicated above, please contact us for further information

How to Read Our Part Number

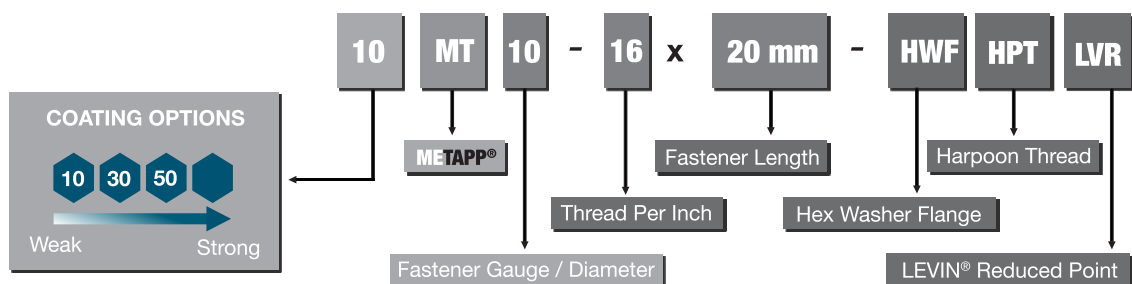

STEEL PENETRATION

Max. 4.5mm thick (For Size 10)
Max. 5.5mm thick (For Size 12)
Max. 6.0mm thick (For Size 14)

ADAPTER TO USE

CORROSHIELD®
Hi-Torque Magnetic Hex Socket

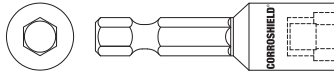

OTHER OPTION/S

Powder coated head to match the colour of roofing sheets

DESCRIPTION

Hex Washer Flange | Hex Washer Head
LEVIN® Drill Point | LEVIN® Drill Point

PRODUCT FEATURE/S

ø 14mm Integrated Flange (HWF)
LEVIN® Drill Point

WASHER OPTION/S

Black/Grey Round Cut EPDM Washer
ø16mm or ø 19mm Aluminum / Galvanised
Bonded Black / Grey EPDM Washer

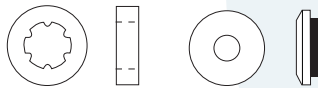

Hex Washer Flange

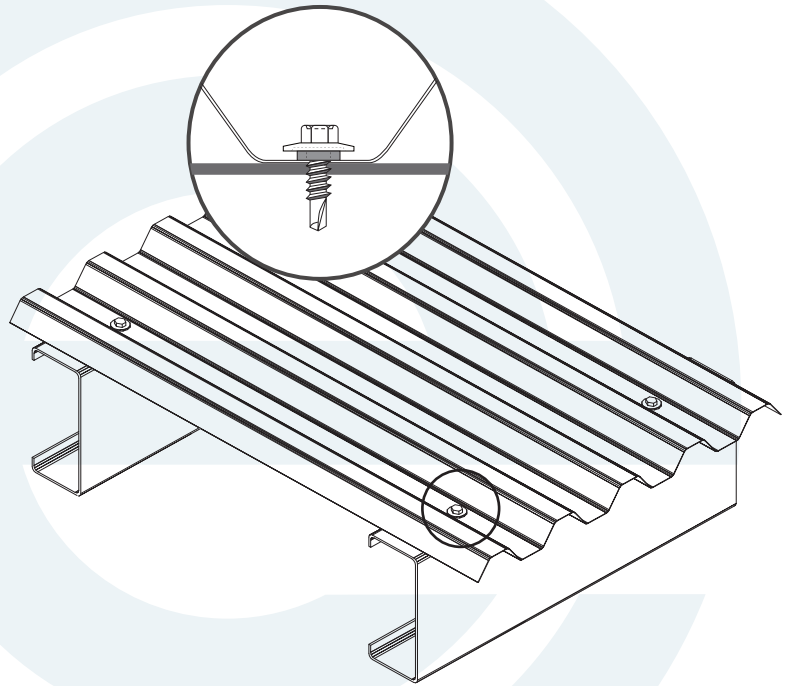
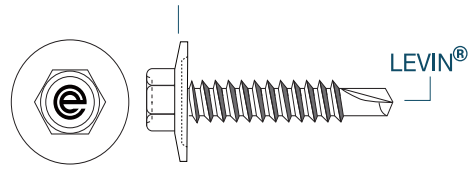

Part Number

- MT 10 - 16 x 25mm MT 14 - 14 x 25mm
- MT 12 - 14 x 20mm MT 14 - 14 x 35mm
- MT 12 - 14 x 25mm
- MT 12 - 14 x 30mm
- MT 12 - 14 x 35mm

* For size not indicated above, please contact us for further information

How to Read Our Part Number

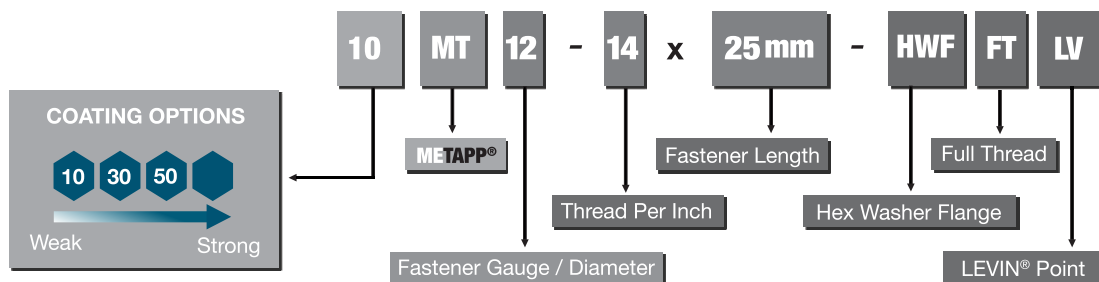

Hex Washer Flange



STEEL PENETRATION

Max. 12.5mm thick

ADAPTER TO USE

CORROSHIELD®
Hi-Torque Magnetic Hex Socket

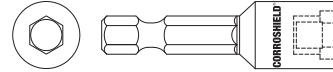

OTHER OPTION/S

Powder coated head to match the colour of roofing sheets

DESCRIPTION

Hex Washer Flange | Hex Washer Head
LEVIN® 5 Drill Point | LEVIN® 5 Drill Point

PRODUCT FEATURE/S

ø 14mm Integrated Flange (HWF)
LEVIN® 5 Drill Point

WASHER OPTION/S

Black/Grey Round Cut EPDM Washer
ø16mm or ø 19mm Aluminum / Galvanised
Bonded Black / Grey EPDM Washer

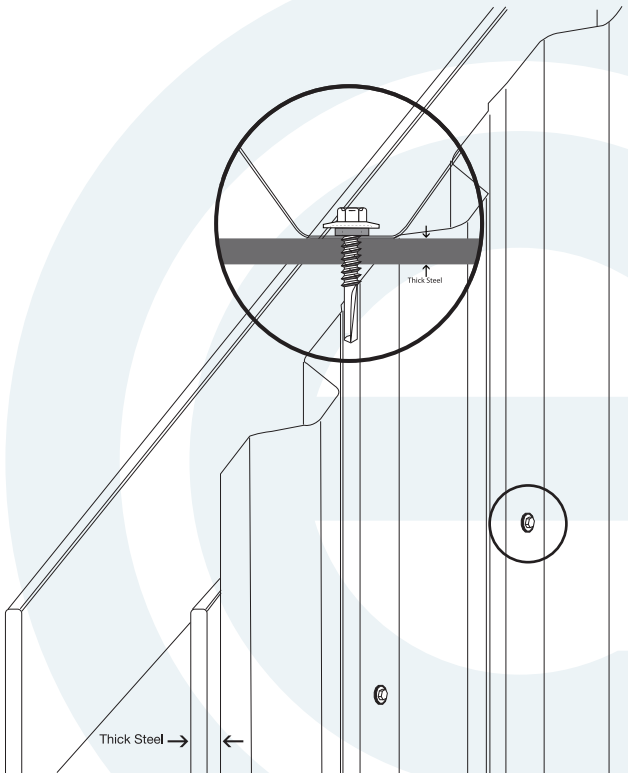
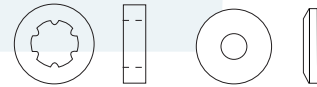

Part Number

MT 12 - 24 x 32mm

* For size not indicated above, please contact us for further information

How to Read Our Part Number

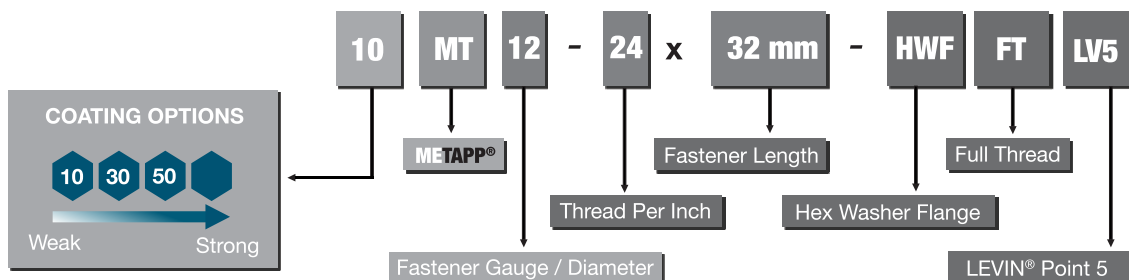

STEEL PENETRATION

Max. 5.5mm thick (For Size 12)
Max. 6.0mm thick (For Size 14)

ADAPTER TO USE

CORROSHIELD®
Hi-Torque Magnetic Hex Socket

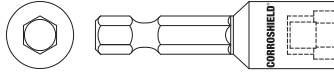

OTHER OPTION/S

Powder coated head to match the colour of roofing sheets
Colour matching for cyclonic washer

DESCRIPTION

Hex Washer Flange | Hex Washer Head
LEVIN® Drill Point | LEVIN® Drill Point

PRODUCT FEATURE/S

ø 14mm Integrated Flange (HWF)
Double Thread | ScratchShield® | LEVIN® Drill Point

WASHER OPTION/S

Black/Grey Round Cut EPDM Washer
ø16mm or ø 19mm Aluminum / Galvanised
Bonded Black / Grey EPDM Washer



We recommend use of cyclonic washer in region where wind speed exceeds 120km/h

Part Number

MT 12 - 14 x 45mm	MT 12 - 14 x 120mm
MT 12 - 14 x 55mm	MT 12 - 14 x 130mm
MT 12 - 14 x 65mm	MT 12 - 14 x 140mm
MT 12 - 14 x 75mm	MT 12 - 14 x 150mm
MT 12 - 14 x 90mm	MT 12 - 14 x 160mm
MT 12 - 14 x 100mm	MT 14 - 14 x 45mm
MT 12 - 14 x 110mm	MT 14 - 14 x 55mm

* For size not indicated above, please contact us for further information

How to Read Our Part Number

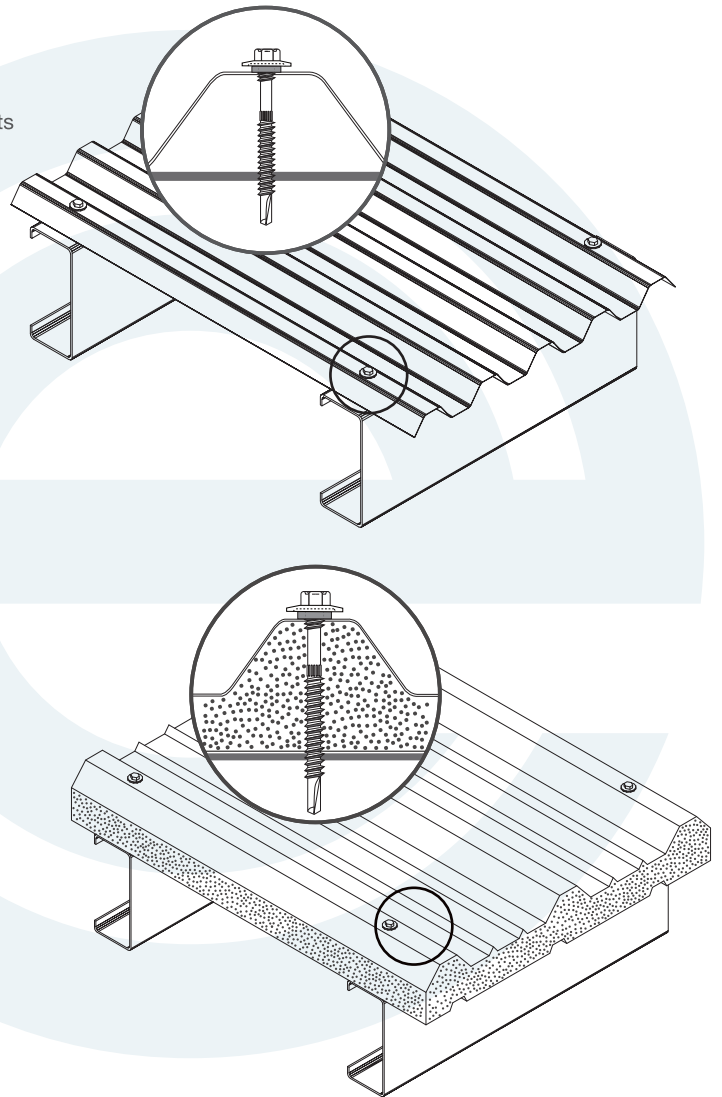
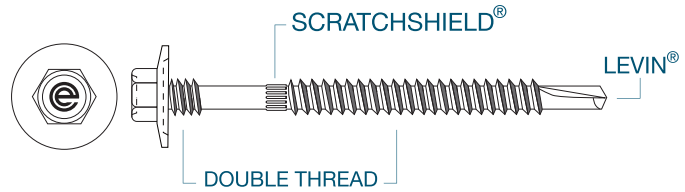
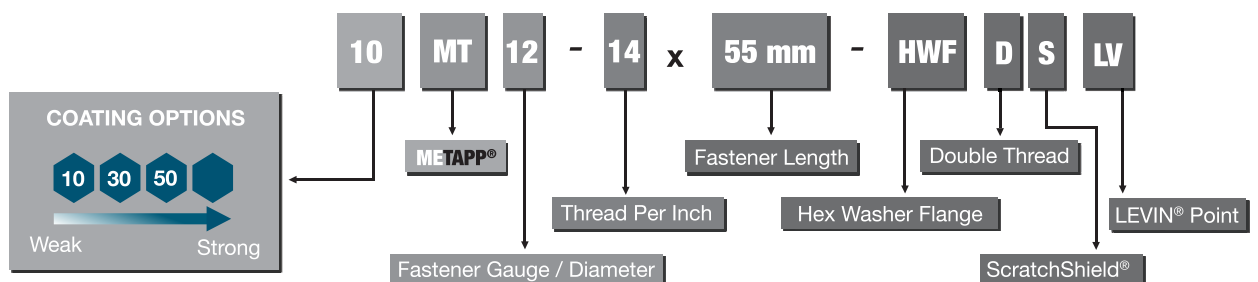

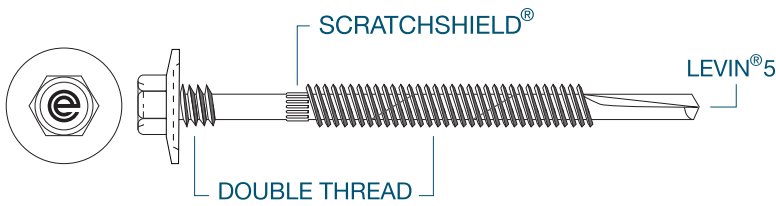

STEEL PENETRATION

Max. 12.5mm thick

ADAPTER TO USE

CORROSHIELD®
Hi-Torque Magnetic Hex Socket

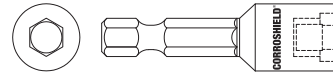

OTHER OPTION/S

Powder coated head to match the colour of roofing sheets
Colour matching for cyclonic washer

DESCRIPTION

Hex Washer Flange | Hex Washer Head
LEVIN®5 Drill Point | LEVIN®5 Drill Point

PRODUCT FEATURE/S

ø 14mm Integrated Flange (HWF)
Double Thread | ScratchShield® | LEVIN®5 Drill Point

WASHER OPTION/S

Black/Grey Round Cut EPDM Washer
ø16mm or ø 19mm Aluminum / Galvanised
Bonded Black / Grey EPDM Washer



We recommend use of cyclonic washer in region where wind speed exceeds 120km/h

Part Number

MT 12 - 24 x 65mm	MT 12 - 24 x 120mm
MT 12 - 24 x 70mm	MT 12 - 24 x 130mm
MT 12 - 24 x 90mm	MT 12 - 24 x 150mm
MT 12 - 24 x 110mm	MT 12 - 24 x 160mm

* For size not indicated above, please contact us for further information

How to Read Our Part Number

